

Body-Solid

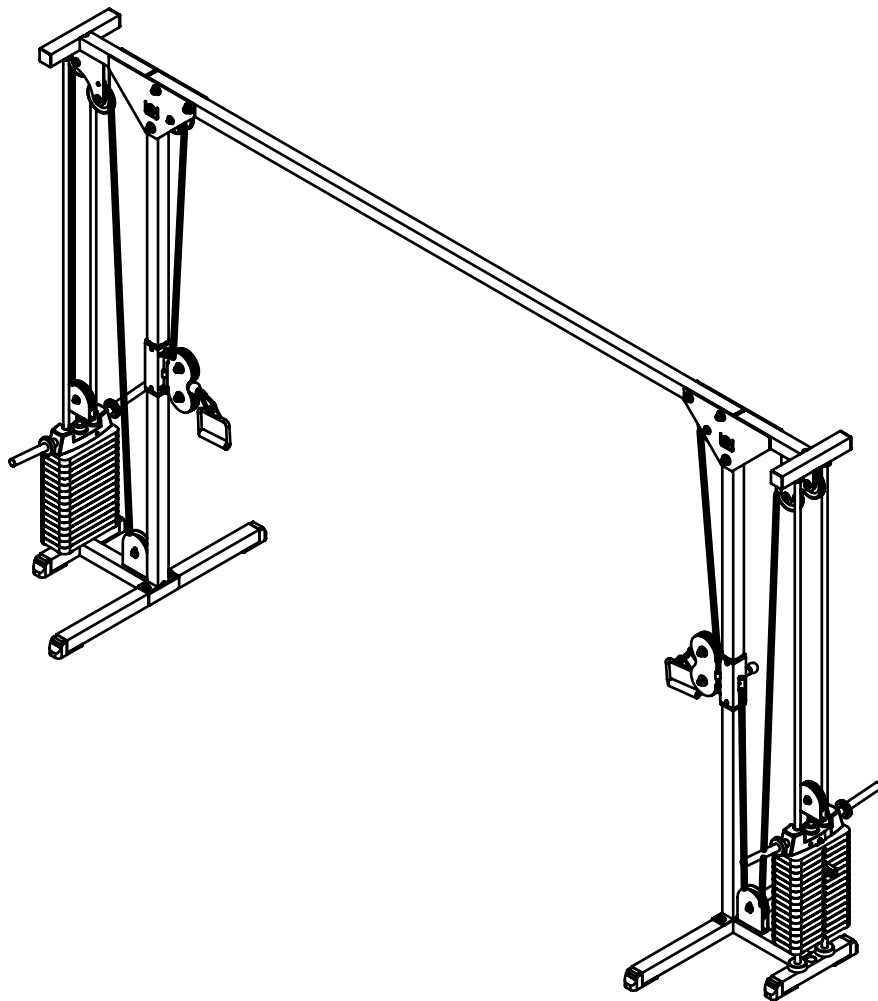

BODY-SOLID, Inc.
1900 S. Des Plaines Ave.
Forest Park, IL 60130 USA
Phone: (708) 427-3555
Fax: (708) 427-3556
www.bodysolid.com

CCO-150.1 OWNER'S MANUAL

CCO-150 ASSEMBLY INSTRUCTIONS

HARDWARE ILLUSTRATION

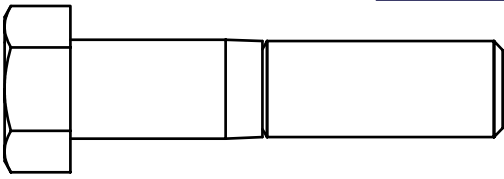

(A1)HEX BOLT 1/2"X2 1/4"L PARTIAL THREAD QTY.4

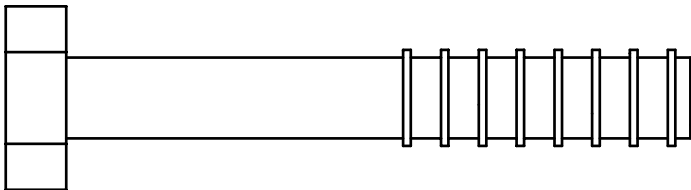

(A2)HEX BOLT 1/2"X3 1/4"L PARTIAL THREAD QTY.8

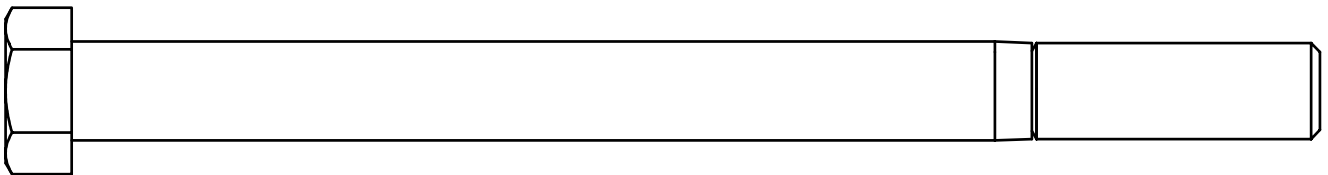

(A3)HEX BOLT 1/2"X6 1/2"L PARTIAL THREAD QTY.2

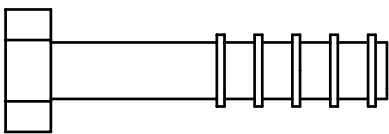

(A4)HEX BOLT 3/8"X1 3/4"L PARTIAL THREAD QTY.8

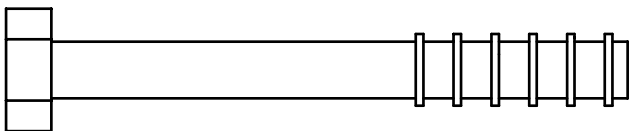

(A5)HEX BOLT 3/8"X3"L PARTIAL THREAD QTY.2

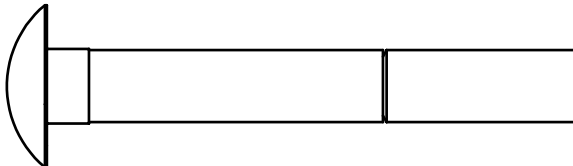

(A6)ROUND HEAD SQUARE NECK BOLT 3/8"X2 3/4"L PARTIAL THREAD QTY.4

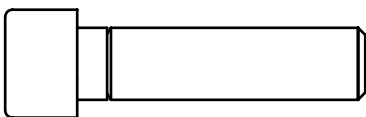

(A7)ROUND BOLT 3/8"X1 1/2"L PARTIAL THREAD QTY.2

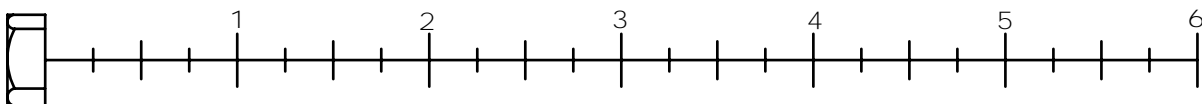

CCO-150 ASSEMBLY INSTRUCTIONS

HARDWARE ILLUSTRATION

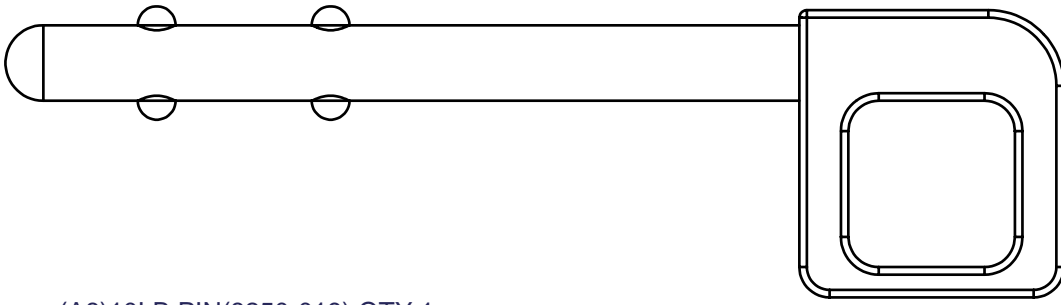

(A8)10LB PIN(8250-019) QTY.1

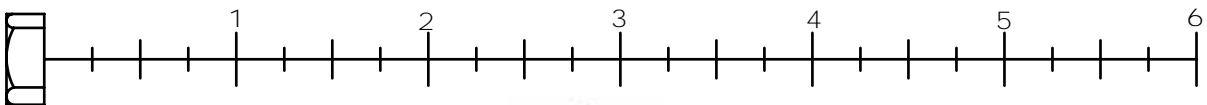

CCO-150 ASSEMBLY INSTRUCTIONS

HARDWARE ILLUSTRATION

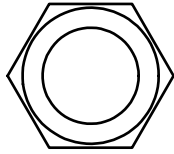
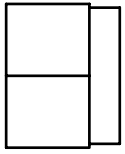

(B1) NYLON LOCK NUT 1/2" QTY.14

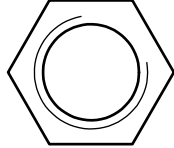
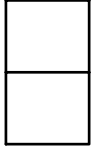

(B2) LOCK NUT 1/2" QTY.2

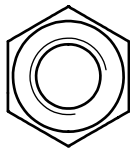
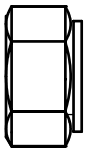

(B3) NYLON LOCK NUT 3/8" QTY.14

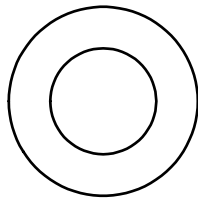

(C1) 1/2" (I.D.) FLAT WASHER \varnothing 25 QTY.4

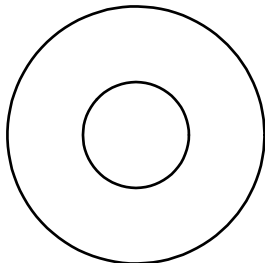

(C2) 1/2" (I.D.) FLAT WASHER \varnothing 34 QTY.24

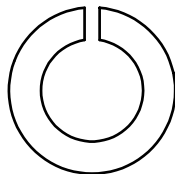

(C3) 1/2" SPRING WASHER QTY.2

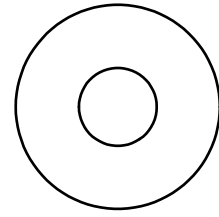

(C4) 3/8" (I.D.) FLAT WASHER \varnothing 27 QTY.24

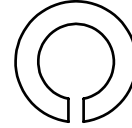

(C5) 3/8" SPRING WASHER QTY.2



CCO-150 ASSEMBLY INSTRUCTIONS

HARDWARE ILLUSTRATION

- D1. 2"X2" END CAP(9211-006)-----[4PCS]
- D2. 2"X2"(2.5t)FOOT CAP(9211-025)-----[8PCS]
- D3. 60x50 NYLON BUSHING(9211-033)-----[4PCS]
- D4. \varnothing 3/4" SHAFT COLLAR(9211-046)-----[4PCS]
- D5. \varnothing 2 1/2" RUBBER DOUNT(9310-010)-----[4PCS]
- D6. \varnothing 2 1/2" RUBBER DOUNT(9310-011) -----[4PCS]
- D7. 130mm PULL UTENSIL(8290-006)-----[2PCS]
- D8. \varnothing 8mm SPRING SNAP LINK(8810-001)-----[2PCS]
- D9. 7330mm STEEL CABLE-----[2PCS]
- D10. WEIGHT SELECTOR BAR(8210-052)-----[2PCS]
- D11. \varnothing 110 PULLEY(9213-002C)-----[8PCS]
- D12. \varnothing 114 PULLEY(9213-010B)-----[4PCS]
- D13. \varnothing 109 PULLEY(9213-022A)-----[2PCS]

D1

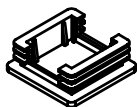

D2

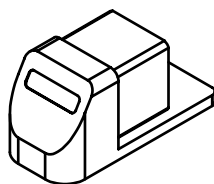

D3

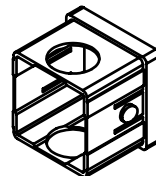

D4



D5



D6



D7

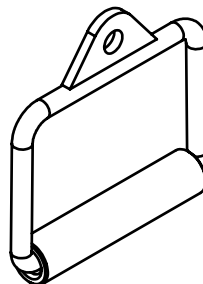

D8



D9

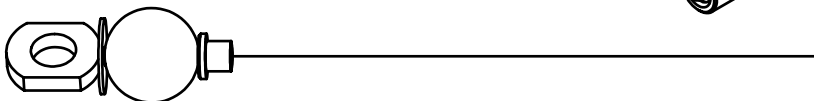

D10

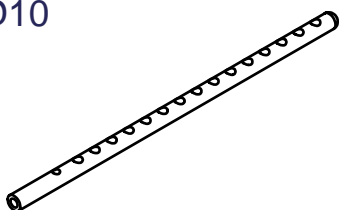

D11

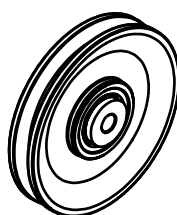

D12

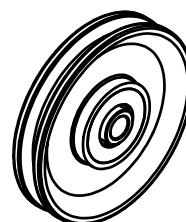

D13

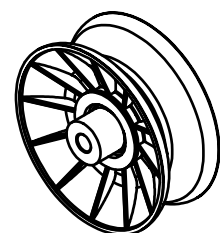

CCO-150 ASSEMBLY INSTRUCTIONS

HARDWARE ILLUSTRATION

D14. TOP PLATE(8400-009)-----[2PCS]

D14

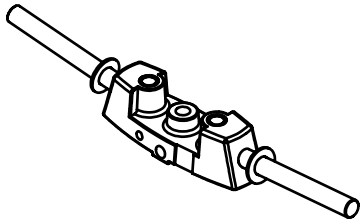

CCO-150 ASSEMBLY INSTRUCTIONS

PARTS ILLUSTRATION SHEET

A[1PCS]

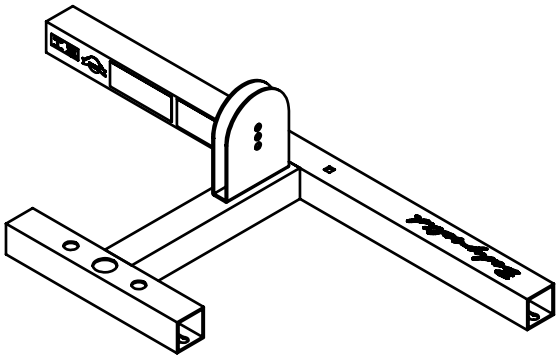

B1[1PCS]

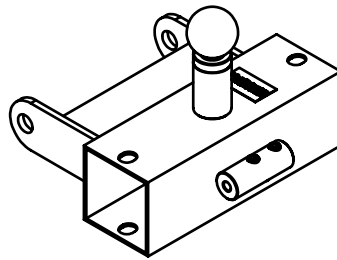

C1[1PCS]

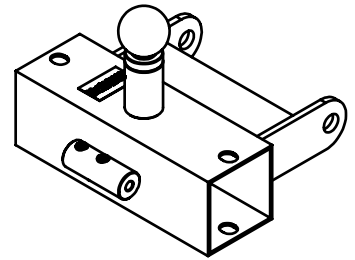

D[2PCS]

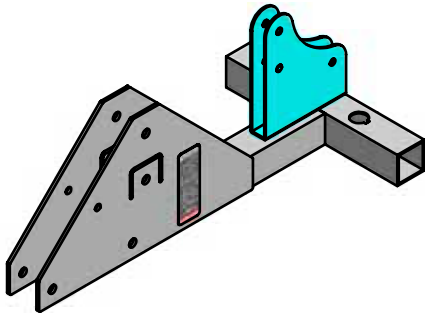

E[2PCS]

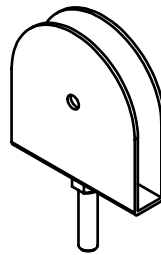

G1[2PCS]

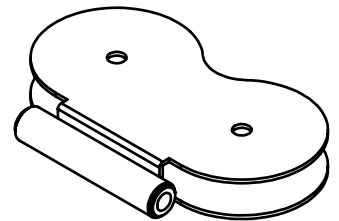

F[1PCS]

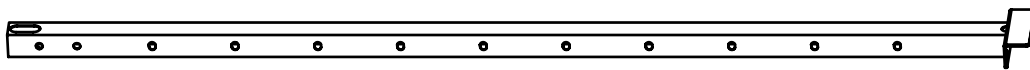

H[1PCS]

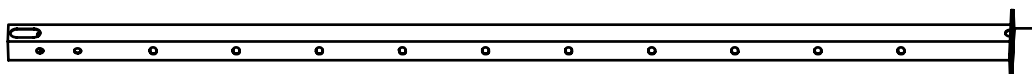

CCO-150 ASSEMBLY INSTRUCTIONS

PARTS ILLUSTRATION SHEET

I[1PCS]

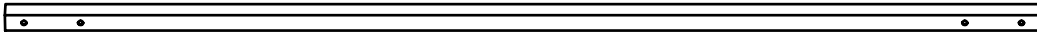

J[4PCS]



CCO-150 ASSEMBLY INSTRUCTIONS

ASSEMBLY STEP 1

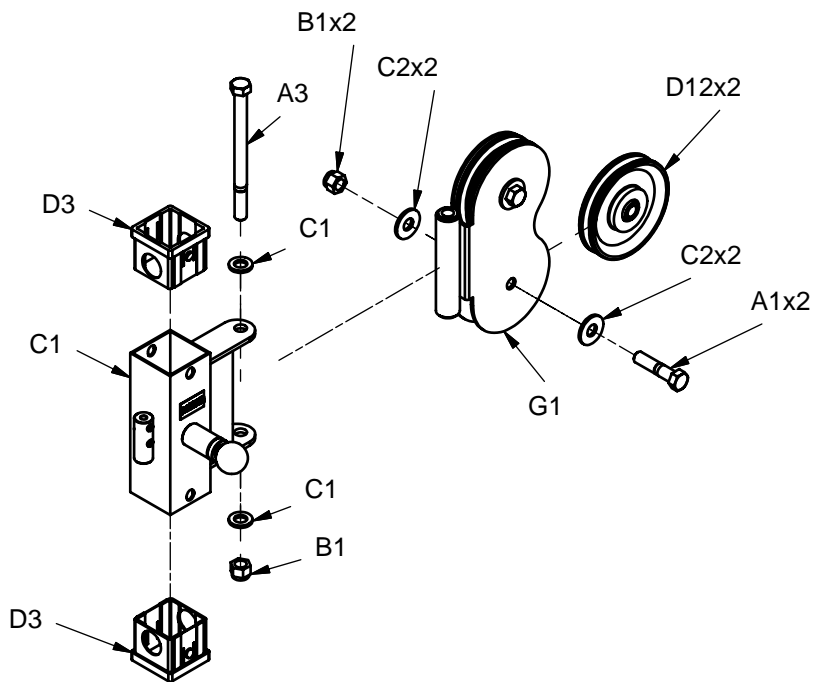
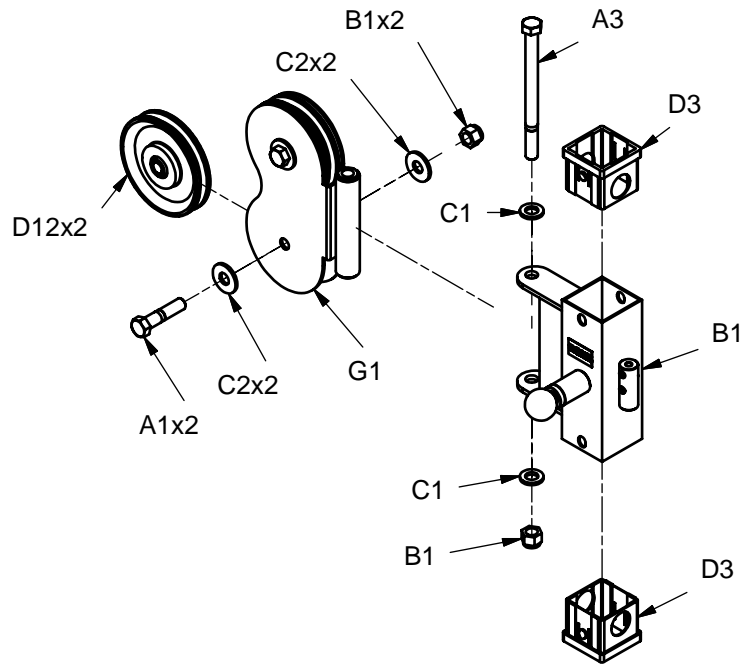

CCO-150 ASSEMBLY INSTRUCTIONS

ASSEMBLY STEP 2

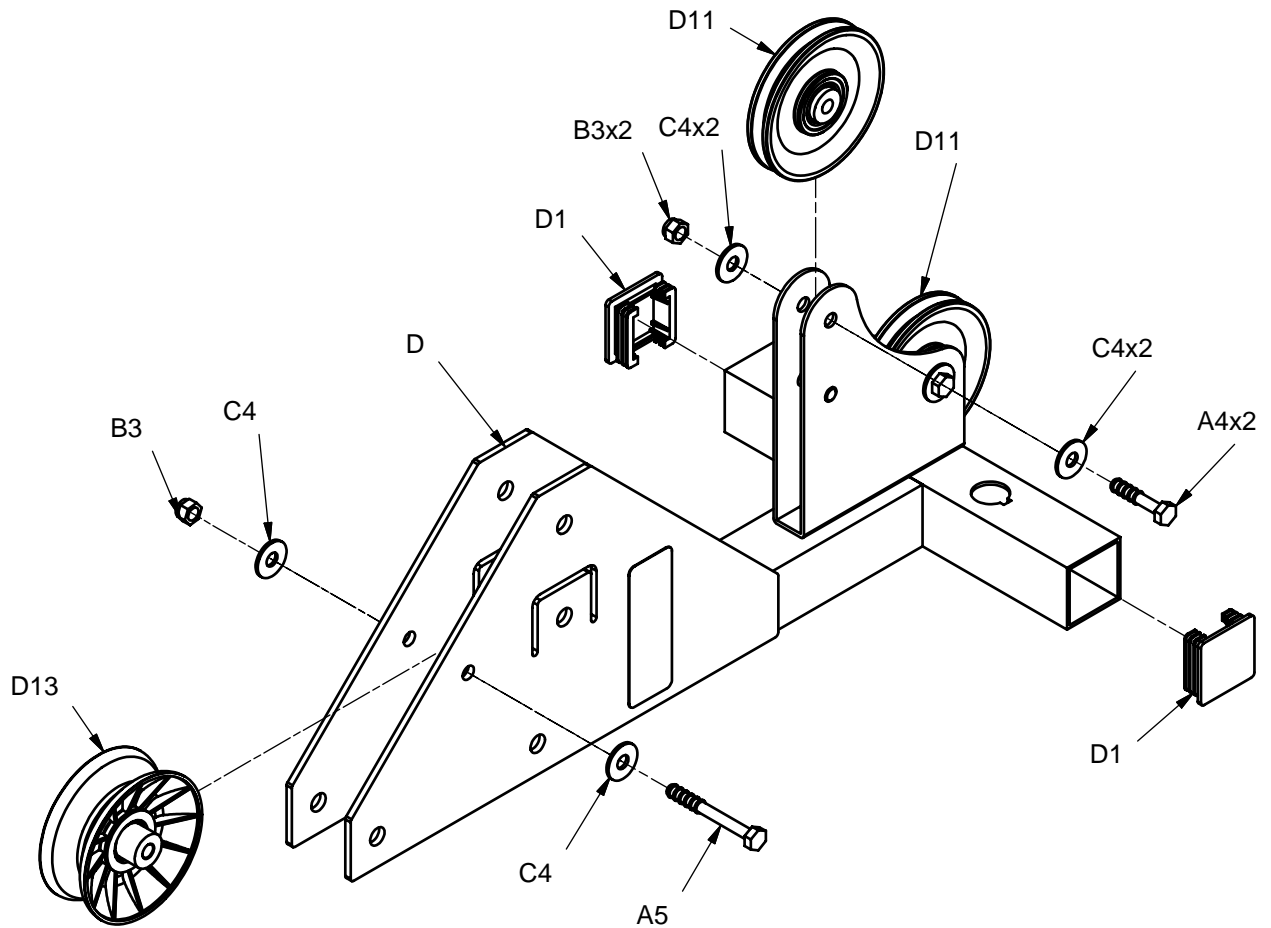

CCO-150 ASSEMBLY INSTRUCTIONS

ASSEMBLY STEP 3

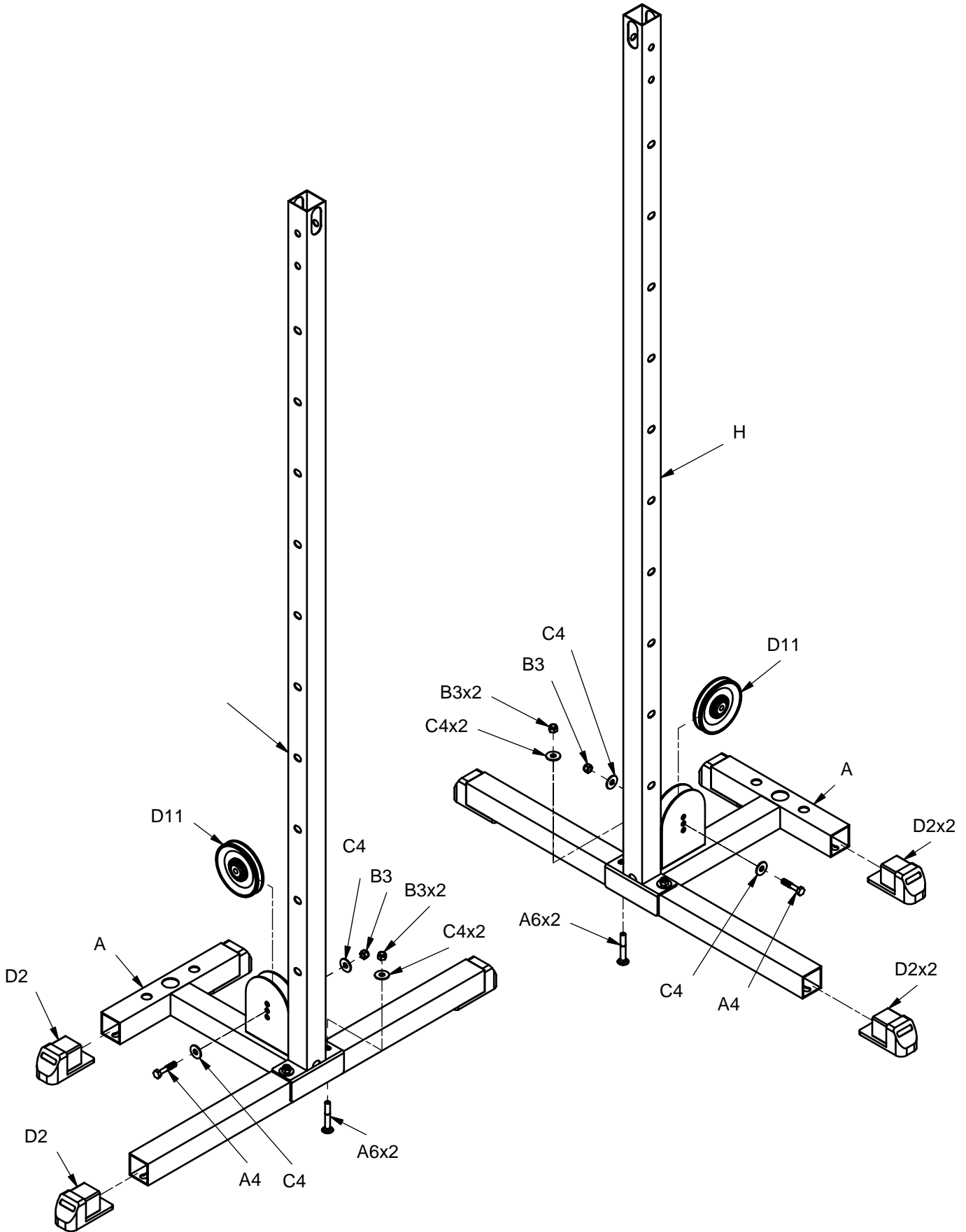

ASSEMBLY STEP 4

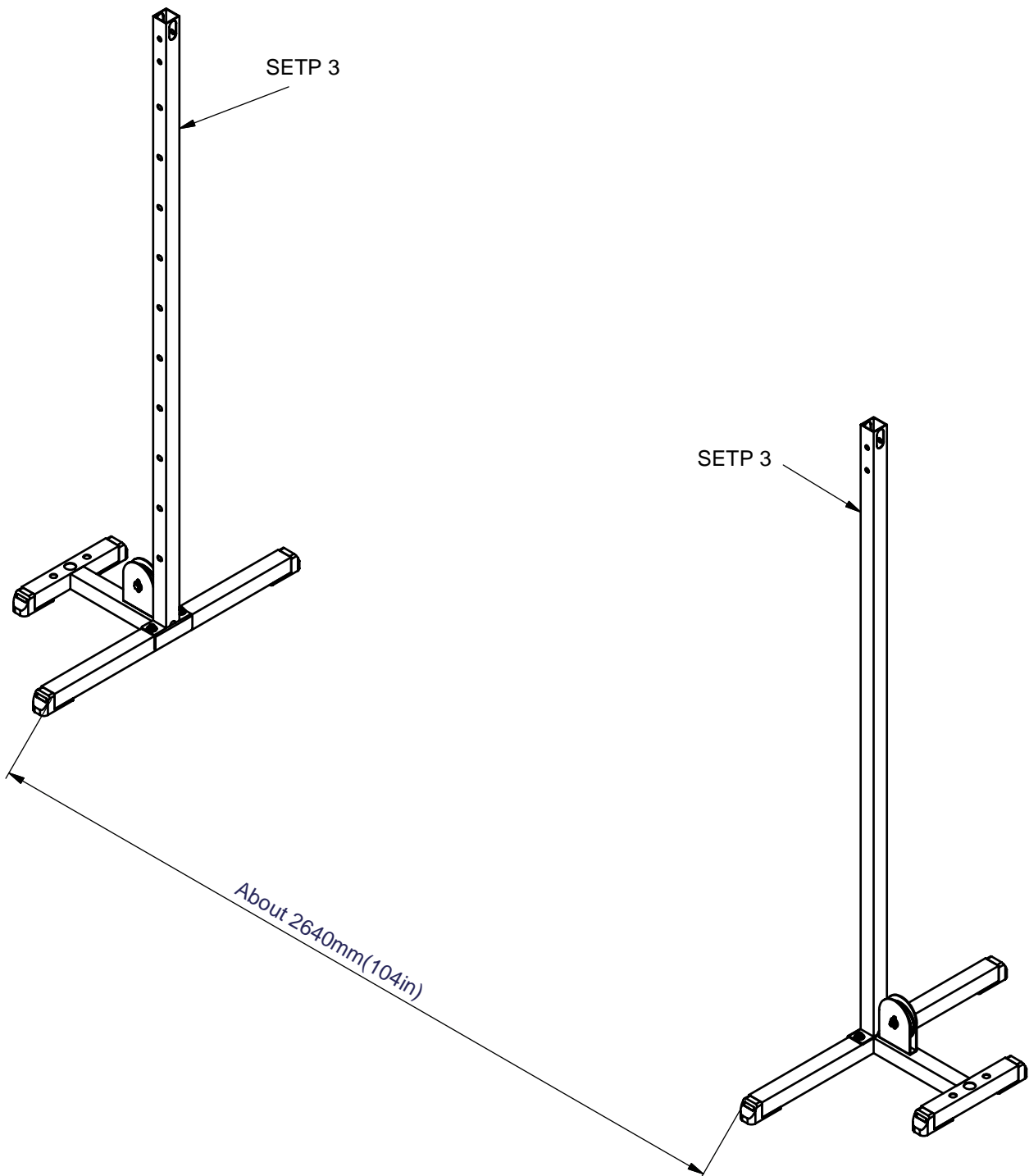

*:Before the assembling of the weight stacks:
Finish (step 3) and adjust the distance between
the two bases to 2640mm(104in)

CCO-150 ASSEMBLY INSTRUCTIONS

ASSEMBLY STEP 5

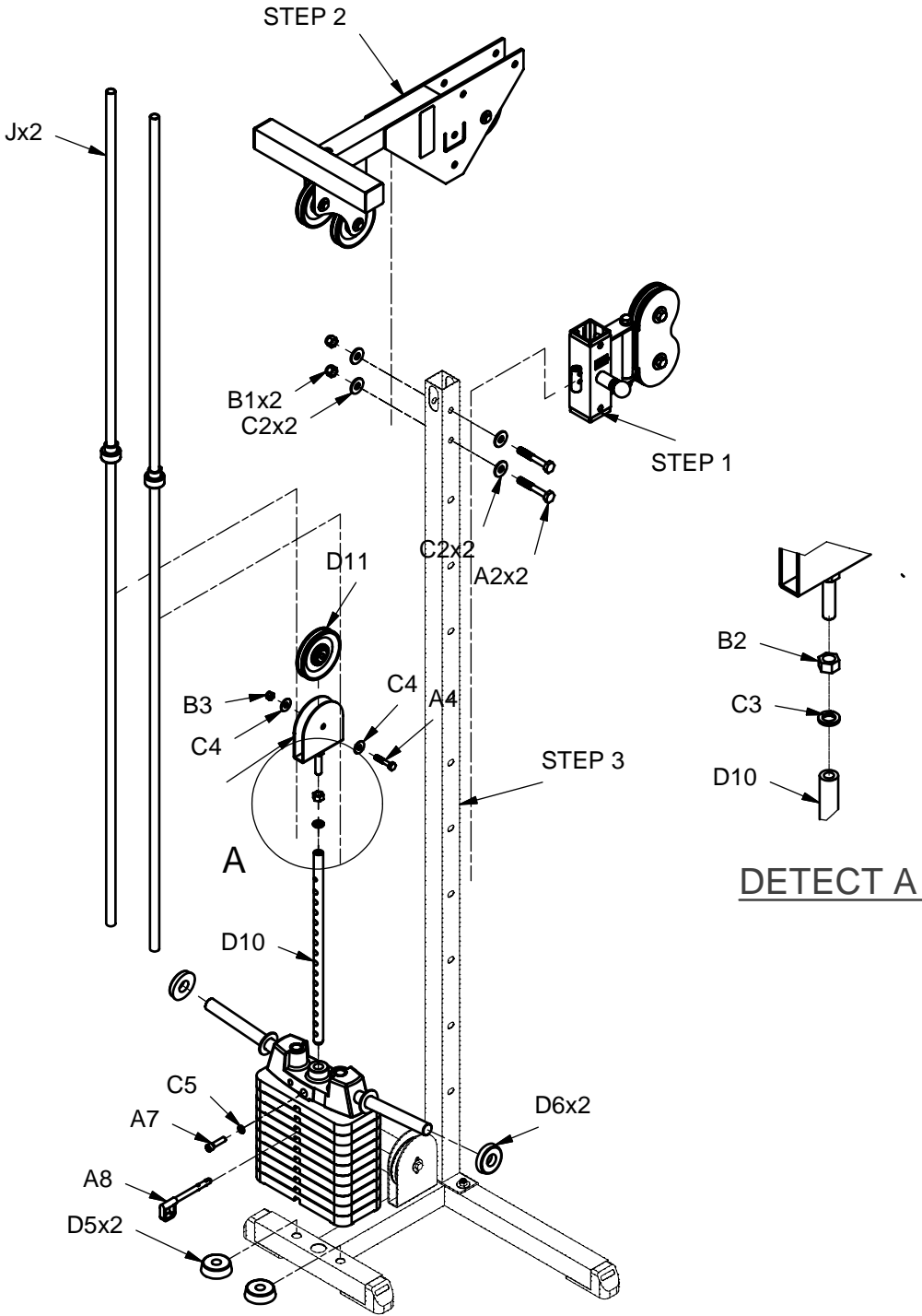

CCO-150 ASSEMBLY INSTRUCTIONS

ASSEMBLY STEP 6

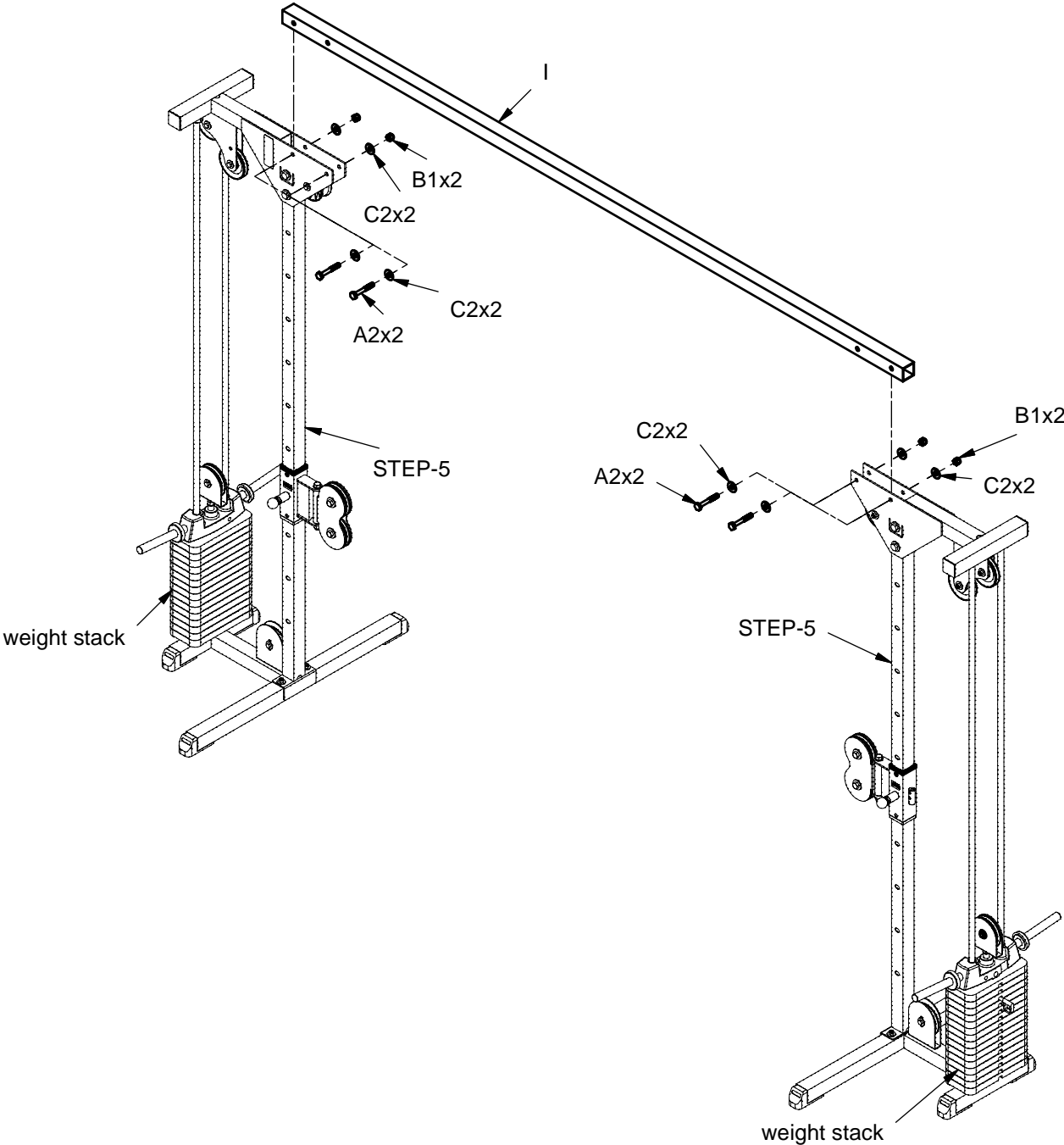

CCO-150 ASSEMBLY INSTRUCTIONS

Wire Rope illustration

